

BM21

PORTABLE BEVELLER

Overview

The BM21 is the latest generation portable bevelling machine, for machining plates and pipes prior to welding. This new and improved design offers a number of innovative solutions that increase ergonomics and ensure even more comfort and work safety of the operator.

Features

- New single milling head equipped with 10 indexable inserts, that makes the machining process far more efficient with little operator's effort
- Extended working range from 0 to 60 degrees with continuous angle adjustment
- Easy setting of chamfer angle and bevel width
- One universal guideline for bevelling both plates and pipes
- Bevells pipes 150 - 300mm diameter, optional attachment available for bevelling pipes 260 - 600mm diameter
- 4 vibration isolators protect both the operator and electronics of the machine against harmful vibration



Maximum Bevel Width

A	0°	15°	30°	45°	60°
B	21mm	18.5mm	18.5mm	21mm	18.5mm

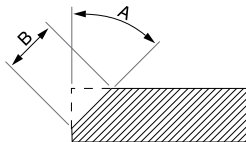

Specifications

Part No.	BM21
Induction Motor	1600W
Max. Bevel Width	21mm
Grinding Angle	0-60°
Rotational Speed	2800rpm
Milling Speed	550m/min
Weight	21kg

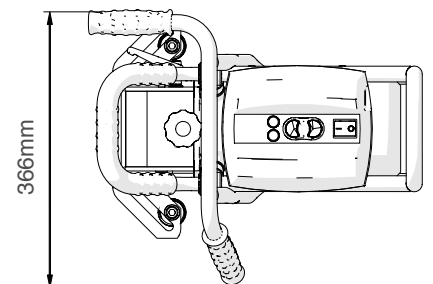
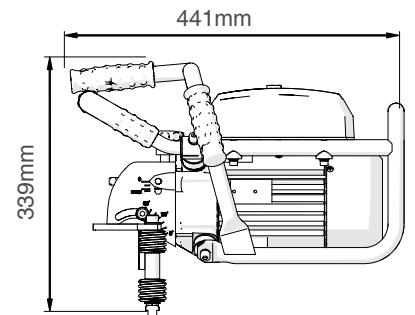

Pipe bevelling



Plate facing-off



Plate bevelling

Optional Accessories & Consumables

- WAP-B020 • Replacement standard cutting tips (10 required)
- WAP-B20/4020 • Large pipe attachment for 260mm - 600mm pipe